

ISS	ZONE	DESCRIPTION \ PER REQUEST \ DATE
-----	------	----------------------------------

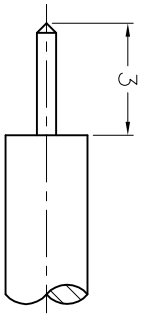

RECOMMENDED  
CABLE STRIPPING DIM'S  
(建議剝線尺寸)

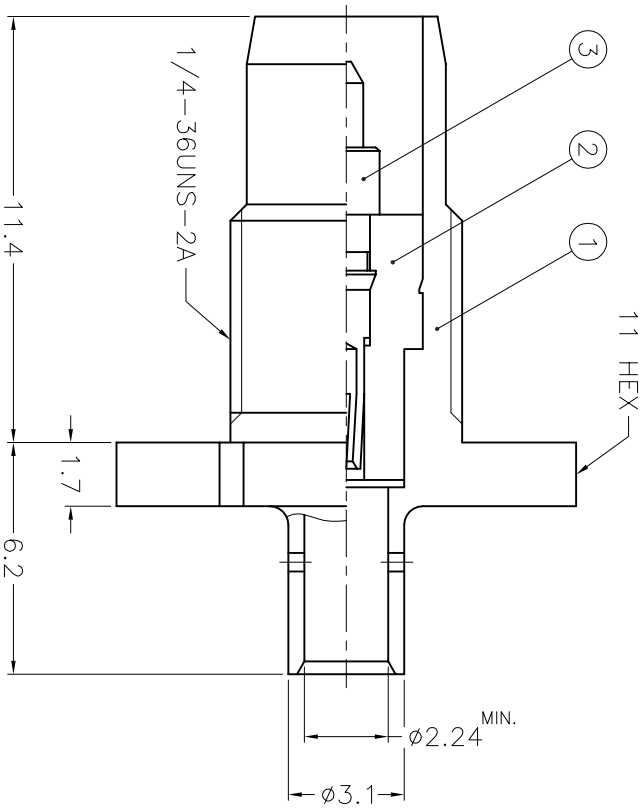
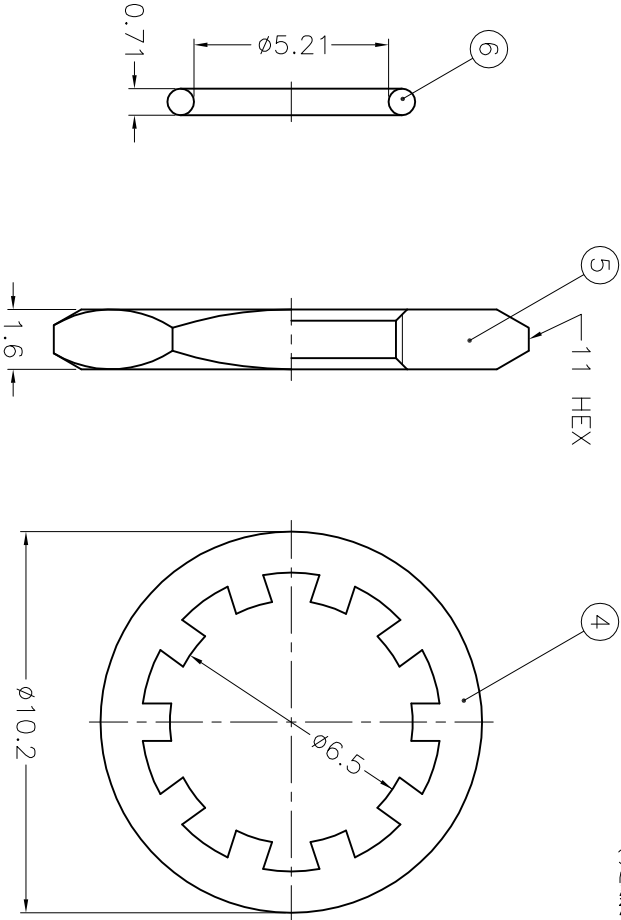

1. MAX. PANEL THICKNESS = 3.2mm

- NOTES: FINISH (PLATING THICKNESS IN MICRO-INCHES)
- BRASS PER QQ-B-626
  - BRASS PER QQ-B-613
  - NICKEL PL. 100 MIN. THICK OVER COPPER STRIKE
  - BERYLLIUM COPPER PER QQ-C-530
  - GOLD PL. 20 MIN. THICK OVER NICKEL PL. 100 MIN. THICK OVER COPPER STRIKE
  - GOLD PL. 50 MIN. THICK OVER NICKEL PL. 100 MIN. THICK OVER COPPER STRIKE
  - STAINLESS STEEL PER QQ-S-764, TYPE 303
  - TEFLON MIL-P-19468

NO.	DESCRIPTION	MATERIAL	FINISH	Q'TY	DRAWING NO.
6	GESKET	EPDM	BLACK	1	615X1681-700
5	HEX NUT	NOTE 1	NOTE 3	1	HN11-1/4-36X16
4	LOCK WASHER	NOTE 2	NOTE 3	1	LW-102/65X05
3	CONTACT PIN	NOTE 4	NOTE 6	1	CP30AAA01A
2	INSULATOR	NOTE 8	NATURAL	1	NS00AGH03A
1	BODY	NOTE 7	NOTE 5	1	BD30AAA01A

DIMENSIONS ARE IN MILLIMETERS	
UNLESS OTHERWISE SPECIFIED	TOLERANCES
0.5-6	= ±0.2
6-30	= ±0.4
30-120	= ±0.6
120-315	= ±1
315-1000	= ±1.6
1000-2000	= ±2.4

PART NO.		DATE	
APPROVED		09-26-02'	
CHECKED		09-26-02'	

DRAWING NO.		DATE	
ANGELA		09-26-02'	

# Amphenol - Kai Jack

TAINAN TAIWAN

TITLE  
BMA BULKHEAD DIRECT SOLDER PLUG  
(FOR 0.85", 0.86")

DRAWING NO.  
KJ-BMA1481A1-S/20GT50G-.085-50

FILE NO.	SCALE	ISSUE	A1
F:\DWG\BMA\1481A1\085-50\520GT50G	5/1		

A

B

C

D

E

F

1

2

3

4

5

6

7

8